



Pumpen Intelligenz.

Wilo domestic products

Home solutions





For every home...

Wilo - for every application

Quality and competence are the cornerstone and foundation of our service capability.















With our continuous research and development, quick processing of orders and advice you can count on, we are your capable partner.

Specialising in the pumping of media, we grew up in the building

systems field, eventually becoming a provider of building systems solutions for hot and cold water applications.

Making products that are easy to install and use are everyday challenges for Wilo.

Key to Symbols

	Heating		Drinking water circulation
	Floor Heating		Solar condensate
	Air conditioning/ refrigeration		Condensing, boiler/air conditioning equipment
	Wastewater/drainage		Self supply of water
	Wastewater/coarse impurities		Rainwater utilisation
	Sewage/faeces		Sprinkler services
	Production water		Sprinkling/irrigation

Wilo-Stratos ECO



High Efficiency Pump

Description

High-efficiency single-head pumps, electronically controlled, with screw connection. These pumps offer continuous differential pressure control for cost effective and safe operation of the heating system in single to six-family houses.

Application

Hot-water heating systems of all kinds, closed cooling circuits, industrial circulating systems.



Approved Fluids

Heating water in accordance with VDI 2035.
Water/glycol mixtures (no more than 50% glycol).
Mixtures with more than 20% glycol content require rechecking of the pumping data.

Technical Data

Performance	
Screwed pumps	10 bar
<i>(Special version: 16 bar operating pressure at $T_{max}=110^{\circ}C$)</i>	
Temperature range	+15 °C to +110 °C
Ambient temperature	+40 °C max. permitted
Motor (ECM technology)	
Mains connection	1~230 V, 50Hz
Protection class	IP44
Insulation class	F
Temperature range	+15 °C to +110 °C



Features

- Programmable control modes p-v for optimum load adjustment
- Automatic setback operation for additional savings potential, for example overnight
- Red button for maximum ease of use
- Thermal insulation shell
- Energy classification 'A'

No jamming thanks to a higher starting torque. Its special ECM technology permits the Wilo-Stratos ECO to generate a starting torque 3 times higher than that of any other heating pump before. This ensures direct starting without a need for servicing, even on re-commissioning after summer shutdown. The ECM technology of the Wilo-Stratos ECO also incorporates an optimised hydraulic system to maximise efficiency. A completely new electronic system constantly controls the Wilo-Stratos ECO in the Δ p-v mode, thus reducing noise generated by flow.

Residual current devices (RCD)

Operation on residual-current devices in accordance with DIN EN 61008-1 is permitted without impairment of the function of the residual-current device (DIN VDE 0160).

Suitable RCD circuit breakers are identified by  or  

Construction

Single-head, high-efficiency pumps for heating applications. Electronically controlled, with screw or flange connection.

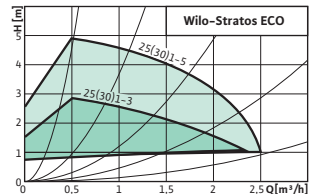

Doubling efficiency: thanks to ECM technology.

Energy is precious. This is why, as early as 2001, the Wilo-Stratos was introduced to the market: the world's first high-efficiency pump. Thanks to ECM technology, this efficient, functional and flexible pump allows a reduction of the annual electricity consumption by up to 80%. ECM means Electronic Commutated Motor. It is based on a synchronous motor with permanent magnet rotor.

Wilo-Stratos: the standard in the energy efficiency class A.

Europe's leading heating pump manufacturers have committed themselves to a uniform labelling of the energy consumption. Consumers already know the energy label from refrigerators and other household appliances.

The energy efficiency classes A to G allow a comprehensive and transparent classification of the pump's consumption data. Energy efficiency class A – this is the class for the Wilo-Stratos. As early as 2001 the quantum leap to the world's first high efficiency pump was made with the Wilo-Stratos and with this, the standard for the new energy label was set.

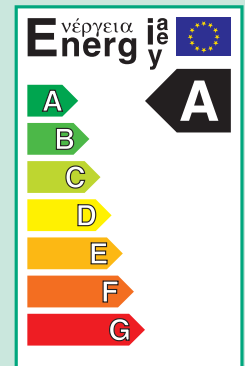

Wilo-Smart



New or replacement circulators for hot water heating systems of any type, underfloor heating, air conditioning systems

Advantages

- Filter and deblocking software for reliable start-up
- Energy Efficiency Class B
- Flexible range of duty (+2°C to +95°C)

The new Wilo Smart offers distinctly more comfort and convenience than any standard pump because it makes flow noises a thing of the past. What's more, it impresses with a considerably wider range of uses. And on top of that it achieves electricity savings of up to 50%.* Replacing an existing pump is now really worthwhile.



Technical Data

Performance	
Patented 3 pre-programmed settings*	
Total Head	max. 6m
Flowrate	max 2.75m/h
Port to Port	130mm
Connections.	1½" BSPM
Max. working pressure	10 bar
Temperature range	+2°C to +95°C
Electrical wiring	
Mains power	1 ~ 230 V, 50 Hz

Quiet Flexible Reliable

Quiet

Automatically adjusts speed to suit demand.
Helps prevent TRV noise.
Automatically adjusts for Summer/Winter system requirements.

Flexible

The intelligent electronic system in the Wilo-Smart automatically adapts the pump's performance and thus the energy consumed to requirements according to the size of the building.

Reliable

The Wilo-Smart's anti-blocking system prevents the rotor and shaft from jamming and therefore ensures highest operational reliability.

Pump Curves

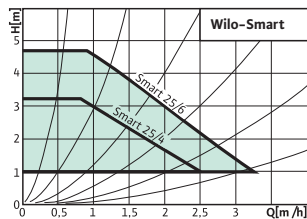

Energy Saving Pump



Easy to connect

Thanks to the Wilo quick connection, the Wilo-Smart is ready for operation in just a few easy steps and without even using a screwdriver: suitable for cable thicknesses up to 2.5 mm.

Easy to install

Pipe connections of 130 and 180 mm diameter permit problem free installation of the Wilo-Smart in any existing system. Flat surfaces on the pump housing provide a secure hold when tightening.

Easy to set up

The Wilo-Smart is very easy to set using three programmes pre-set at the factory.

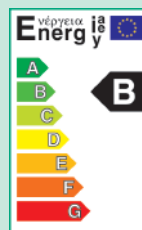

Energy efficient

Thanks to its electronic control system and the latest motor and hydraulic technology, it impresses with electricity savings of up to 50%.* This is why our pump has been awarded the accolade of Energy Efficiency Class B.

*Compared to uncontrolled heating pumps.

Wilo-Gold RS



New or replacement circulators for domestic heating systems

Description

The Wilo Gold Range of manual 3 speed Domestic circulators comprises the 5 metre head Wilo-Gold RS 50 which is suitable for virtually all standard domestic heating systems and the Wilo-Gold RS 60 with a 6 metre head. The Wilo-Gold RS 60 offers ample power to provide a satisfactory performance when fitted in systems using high efficiency boilers as well as the latest design of radiators.

Approvals



The circulators are manufactured in what is probably the most advanced factory in Europe and Kitemarked to EN 60-335-2-51 1991 and BS 1394: 1987. The factory operates a quality assurance system which is approved to BS EN ISO9001 (formerly BS5750 Part 1). Wilo (U.K.) Ltd are also operating a quality assurance system which is approved to BS EN ISO9002 (Formerly BS 5750 Part 2). This ensures that our product offers the highest standard of quality and reliability throughout the supply chain - from research and design to manufacture and supply in the UK.



Application

The range is suitable for new or replacement applications up to around 35KW (120,000 B.T.U.'s). The Wilo-Gold RS 60 offers ample power for satisfactory performance when fitted in systems using high efficiency boilers as well as the latest design of radiators. (These types of boilers and radiators offer higher resistances than their traditional counterparts).

Technical Data

Performance		
Manual 3-speed setting	Gold RS50	Gold RS60
Total Head	5 metres	6 metres
Flowrate [m ³ /h]	3.2	3.5
Port to port	130mm	130mm
Connections [BSPM]	1½"	1½"
Max. working pressure	10 bar	10 bar
Temperature range	-10°C to +110°C	
Electrical Wiring		
Mains power	1~230 V, 50Hz	

Reliability Safety and Efficiency

The Gold range is exceptionally quiet in operation. The design of the electric motor produces a high starting torque which, combined with the special stainless steel hollow shaft, reduces the potential for the circulator to stick due to foreign matter in the heating circuit. All Wilo-Gold® RS circulators come with a warranty of 24 months from date of manufacture.

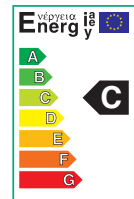
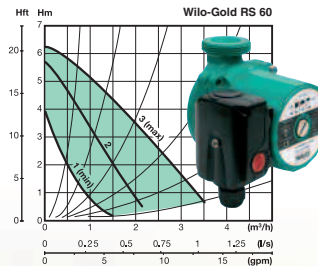
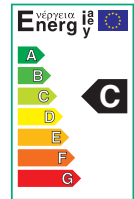
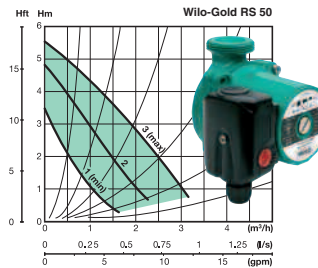

Energy Efficiency

Both the Wilo-Gold RS 50 and Wilo-Gold RS 60 achieve high energy ratings making them an ideal choice in the domestic environment.

*Europe's Favourite
Circulator*

So when it comes to choosing a new or replacement circulator for domestic Central Heating Systems, the Wilo-Gold® RS has the perfect combination of features that deservedly warrant the title 'Europe's Favourite Circulator'.

Wilo-Stratos ECO-Z



Single-head pump
(Secondary hot water).

Description

Single-head pumps high-efficiency pumps for secondary hot water circulation, electronically controlled, with screw or flange connection. These pumps offer continuous differential pressure control for cost effective and safe operation of the heating system in single to six-family houses.

Application

Secondary hot water circulation systems of all kinds, hot water heating systems of all kinds.



Features

- Automatic setback operation for additional savings potential, for example overnight
- Brass bodied pump housing
- Thermal insulation shell
- Energy classification 'A'

Approved Fluids

Secondary hot water and water for food processing in accordance with TrinkwV 2001 up to 20 °d at +80 °C.
Heating water in accordance with VDI 2035 up to +110 °C.
Water/glycol mixtures (no more than 50% glycol).
Mixtures with more than 20% glycol content require rechecking of the pumping data.

Pump Curves

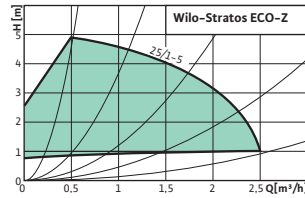

Technical Data

Performance

Screwed pumps	10 bar
Flanged pumps	6/10 bar
<i>(Special version: 16 bar operating pressure at Tmax=110°C)</i>	

Permitted temperature range

Drinking water	up to 20 °d max. +80 °C
Heating water	+15 °C to +110 °C



Ambient temperature +40 °C max. permitted

Motor (ECM technology)

Mains connection	1~230 V, 50Hz
Protection class	IP44
Insulation class	F

Residual current devices (RCD)

Operation on residual-current devices in accordance with DIN EN 61008-1 is permitted without impairment of the function of the residual-current device (DIN VDE 0160).

Suitable RCD circuit breakers are identified by  or  

Wilo-Stratos: the standard in the energy efficiency class A

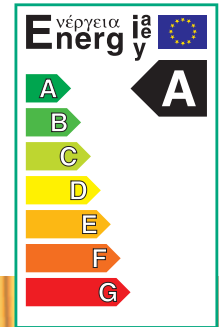

Wilo-SB



Bronze, Glandless In-line Circulator

Secondary hot water applications.

Description

The Wilo SB® range comprises just four bronze bodied circulators providing the installer with an ideal solution to the majority of secondary hot water service applications. These circulators are easy to fit and energy efficient in operation. All SB models can be fitted with the optional timer control** that allows the on/off function to be programmed so that the circulator operates only when required. All SB models are fitted with non-overloading motors and thus require no external motor protection.

** Note: When fitting timer, the unit operates at maximum speed only.

Application

The SB range is suitable for both new or replacement work and can be used with chilled water down to -100°C as standard due to the condensation proof design.

Technical Data

Performance Manual 3-speed setting	SB5	SB30(SB30G)	SB60
Total Head	1 metre	5 metres	6 metres
Flowrate [m³/h]	2.25	4.3	5.3
Port to port [mm]	130	130(150)	180
Connections [BSPM]	1"	1½"(1¾")	1½"
Max. working pressure [bar]	10	10	10
Temperature range	-10°C to +110°C		

Electrical wiring

Mains power 1~230V, 50Hz



Ease of use

Switch designed to facilitate easy speed selection from the front face of the circulator. captive terminal box cover fixing screw. Earth, live and neutral connections accessible from front face to allow easy wiring of the unit. Replaceable capacitor.

Construction

The SB circulators are of the glandless design with the rotating parts running in the liquid being circulated. This principle can be seen in this sectional illustration.

The unique hollow ceramic shaft and sintered bronze filter serve to maximise the running hours ensuring long and trouble free service. The ceramic shaft minimises the build up of calcium based salts, whilst the sintered bronze filter serves to remove any harmful debris from the water before it is circulated around the rotor and bearings.

Wilo-SB – for new and replacement operation

Approvals

All SB models have WRc approval. These circulators are manufactured in what is probably the most advanced factory in Europe. The factory operates a quality assurance system which is approved to BS EN ISO 9001 (formerly BS5750 Part 1). Wilo (U.K.) Ltd also operate a quality assurance system which is approved to BS EN ISO 9002 (formerly BS5750 Part 2). This ensures that our product offers the highest standard of quality and reliability with an unbroken supply chain – from research and design, to manufacture and supply in the UK.

- WRc approved
- Suitable for new and replacement
- Condensation proof design as standard (-10°C to +110°C)
- Unique hollow shaft and sintered bronze filter ensures long, trouble free operation
- Non overloading motor
- Optional plug in timer for Legionellae protection

WILO-SB30, SB30G

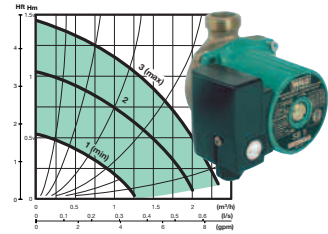

WILO-SB5

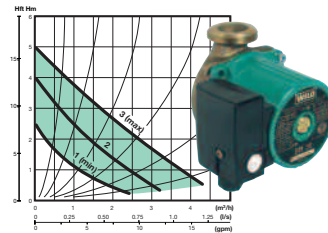

WILO-SB60

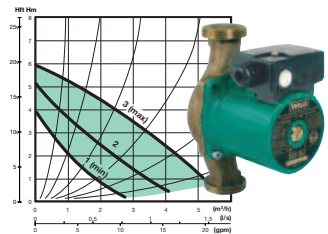

Wilo Bronze Circulators help to kill off Legionellae

The circulator acts as an anti-stratification device and is particularly suitable for hospitals, residential homes for the elderly and sheltered housing which use high volumes of water. It would normally be installed as part of a secondary hot water system which involves a separate ring main operating independently from the primary central heating circuit. The main purpose of a secondary system is to ensure that there is always a constant supply of hot water available instantly at the various draw-off points with no cold "dead legs" in the circuit. However, an additional application for the "SB" series is that the circulator – which is available with an integrated timer clock – is fitted to a loop of pipework on the side of the actual hot water storage calorifier. Hot water will generally kill off legionellae bacteria but problems arise, particularly for high risk categories such as the young, sick and elderly especially when the circuit is not in constant use. This can lead to stratification in the storage tank – with hot water at the top and a cold layer at the bottom. Bacteria breed and multiply in the cold section and are then drawn off when the system again comes into use. This is eliminated by setting the time clock on the circulator to induce circulation automatically at times of low demand – usually during the night – to maintain the temperature of the water at an even level of 60°C at which temperature the bacteria will be killed off.

Wilo-SE



Glandless In-line Circulator
Heating pump application.

Description

The WILO-SE® range of products are designed and marketed primarily to simplify the replacement of existing circulators and are packaged to ensure that the vast majority of existing circulators can be replaced immediately without the need for expensive and time consuming pipework alterations. With the exception of the WILO-SE® 110 and the WILO-SE® 125 TW, each unit is supplied complete with the necessary washers or gaskets, nuts, bolts and spacer kit which gives the installer the opportunity to replace existing circulators, whether they be traditional 244mm port to port or European 250mm port to port dimensions.

New Installations

To use the WILO-SE® range for new installation work, the WILO-SE® range of accessories are available and comprise a pair of unions for the WILO-SE® 125 and for the WILO-SE® 150 and 200 models the correct counterflanges for the application, whether single or twin head. These accessories are packaged and clearly labelled and as with the circulators are competitively priced to ensure that the installer can simply effect installation both efficiently and profitably.

As previously detailed the WILO-SE® 110 and WILO-SE® 125TW are supplied complete with the necessary unions and are therefore totally packaged suitable for new or replacement work.



Technical Data

Performance	SE110	SE125(TW)	SE150(TW)	SE200(TW)
Manual 3-speed setting	•	•	•	
Total Head (m)	4	5.5(5.5)	4(5.1)	7(7)
Flowrate [m³/h]	9	5.8(5.0)	9 (7.8)	10 (10.5)
Port to Port (mm)	180	180(180)	244(244)	244(244)
Connections.[BSPM]	2"	1½" (2")	40mm flange	
Max. working pressure	10bar			
Temperature range	-20°C to +130°C			
Protection Class	IP44			

Electrical wiring	
Mains power	1~230V, 50Hz

NOTE: Figures in brackets () apply to twin model type listed above where data varies from the single head model.

Accessories

Type (2+flanges, gasket, nuts and bolts)	Article No.
40mm counter flanges for SE 150/200 (40mm PN16)	002 815 125
50mm counter flanges for SE 150/200 (50mm PN6)	002 815 112
1.5" x 1.25" unions for SE 125	002 815 102
Blanking plate to suit SE 125	309 081 74W
Blanking plate to suit SE 150/200	309 117 21M

(Delivery code L – Available ex-stock UK)

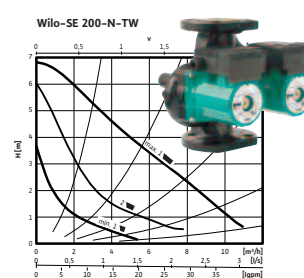
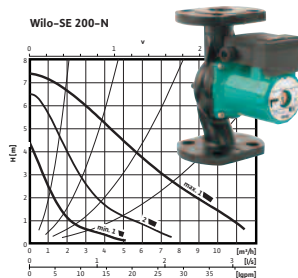
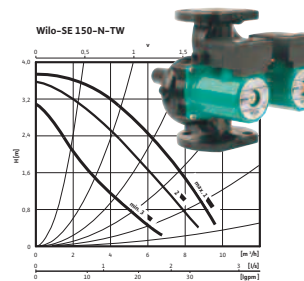
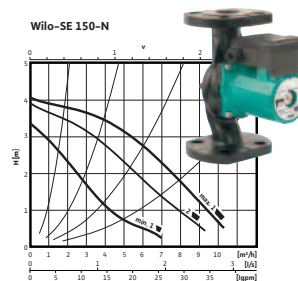
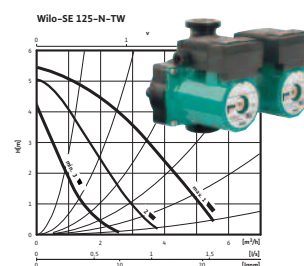
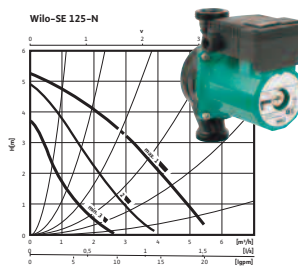
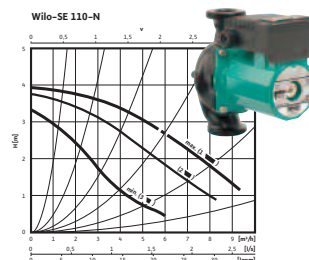

Wilo-Star-Z15TT



Secondary hot water pump

Description

Hot water should be available from the tap instantly and at any time. Since the water outlet is often a long way from the hot water tank, it can take a long while before all the cold water in the pipes has been let out so that the hot water can emerge. The new Wilo-Star-Z 15 TT drinking water circulation pump ensures that you always have instant hot water. When incorporated into the drinking water heating system, the Wilo-Star-Z 15 TT also provides extra protection against Legionnaire's disease and the Legionella bacteria.

- Three time slots per day
- Temperature – hold and set
- Blockage protection

Diseases and epidemics caused by water-borne bacteria were known already in the days of the Roman empire. These bacteria multiply especially if the water stagnates at a temperature between about 25 and 50°C. Particularly dangerous to human beings is the Legionella bacterium, which causes Legionnaire's disease discovered in 1976 in the US. Thriving in warm, stagnant water at temperatures between 25°C and 50°C, this pathogen spreads like wildfire under these conditions. While remaining harmless in drinking water,

Legionellae become dangerous when inhaled with water spray. An excellent means of counter-acting this hazard is the Wilo-Star-Z 15 TT, the only drinking water circulation pump supporting automatic, thermal disinfection of warm-water reservoirs and thus providing effective protection against Legionellae.

Application

Drinking water circulation systems and similar systems in industry and building technology (e.g. cooling water circulation) The Wilo-Star-Z 15 TT features an integrated thermostat that automatically maintains the temperature to a specific reference when so specified by the operator. Water quality optimized in this way means that drinking water regulations are constantly maintained.



Pump Curves

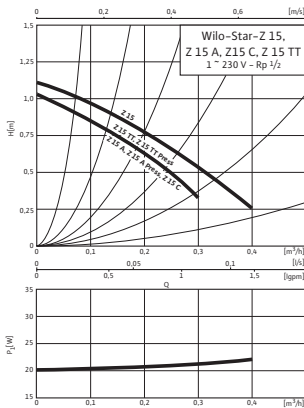

Technical Data

Performance	Star-Z 15 TT	Star-Z 15 TT Press
Maximum motor speed (constant)	2600 1/min	
Nominal width of connection pipe	R1	Ø 15 mm
Fitting length	138 mm	166 mm
Max. operating pressure	10 bar	
Connections.[BSPM]	40mm flange	
Max. working pressure	10bar	
Minimum input pressure at the suction port at a temperature of 65°C *	0.2 bar	
Permissible temperature range of the flow medium	20°C to 65°C, in short time mode (approx. 2 hrs) 70°C	

* This value is applicable up to 300 m above sea level, addition for higher values: 0.01 bar/100 m height increment.

Electrical wiring

Mains power	1~230V, 50Hz
-------------	--------------

Extra protection against Legionellae

Thermal disinfection automatically ensures an early eradication of any Legionellae present in drinking water: The water is heated to roughly 70°C over a pre-defined period at night. Because the circulation pump might be inactive during this period, a routine is needed to detect this

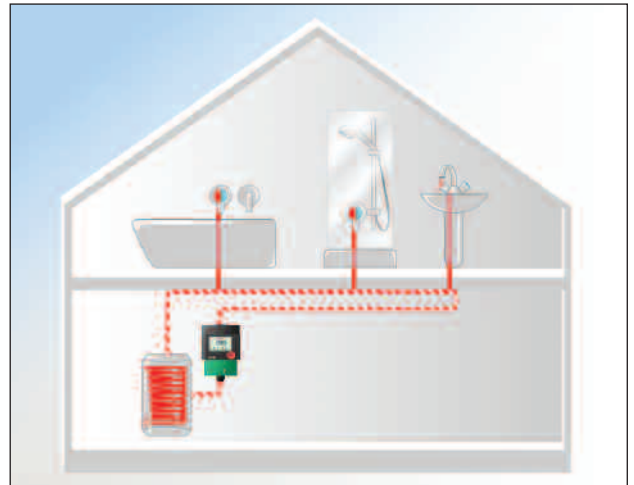

heating process and activate the pump irrespective of the timer setting in order to rinse the pipeline with hot water too. The Wilo-Star-Z 15 TT proves extremely beneficial here, guaranteeing hygienically clean water at all times.

Wilo-SilentMaster



A new generation of intelligent centrifugal pump

Description

The Wilo-SilentMaster is an exceptionally quiet pump, combining innovative design and a patented cooling system, 43 db(A) is within easy reach. In combination with its small dimensions and its appealing design it is the ideal solution for domestic applications where it can be installed in a kitchen or in a cupboard.

Thanks to dry-running protection and an integrated non-return valve, the Wilo-SilentMaster is as reliable as it is quiet – an 'all in one' portable concept designed for ease of use in domestic situations.

That's what we call **Pumpen Intelligenz**.

Technical Data

Performance	
Max. service pressure	8 bars
Min/Max suction pressure	-0,8 to 4 bars
Water temperature	5 - 35°C
Max. ambient temperature	40°C
Max. suction height	8m
DN suction	1"
DN discharge	1"
Sound level	43 db(A) (-0/+3)

Electrical wiring	
Mains power	1~230V, 50Hz

Application

Self-supply of water, sprinkling, spraying and irrigation for well, river lake and rainwater (clean particle free rainwater only). Ideally installed inside the house, the Wilo-SilentMaster is made for pressure boosting and rainwater utilisation. This pump is also suitable for drinking water.

- Quiet operation 43 db(A)*
- Dry running protection
- Compact design and construction
- Easy installation
- Non overloading motor
- High operating safety
- Stainless steel pump inside
- Ideal solution for applications in one and two family houses

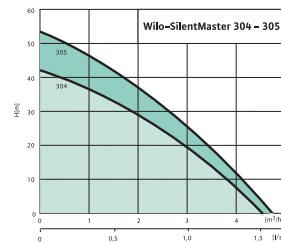

Materials of construction	
Impellers	Noryl
Stages	Noryl
Mechanical seal	Ceramic/carbide
Pump casing	Stainless steel 304
Pump shell	PP
Shaft	Stainless steel 420

Specification

Packaged centrifugal pump set with end suction and vertical discharge ports consisting of:

- Low noise self-priming multi-stage horizontal high pressure centrifugal pump with common motor/pump shaft and seal
- Directly flange mounted single-phase motor with integrated thermal overload switch and capacitor

- Acoustic shell cover that can reach a sound level of 43 db(A). Its integrated non return valve allows an excellent priming of the pump

This pump is electronically driven, it prevents the pumps from dry running and communicates all the defaults and status to the end user.

* Approx decibel comparisons
 0 db - Threshold of Hearing (TOH)
 40 db - Refrigerator humming (TOH⁴)
 60 db - Normal conversation (TOH⁶)
 130 db - Pain threshold (TOH¹³)

Pumpen Intelligenz

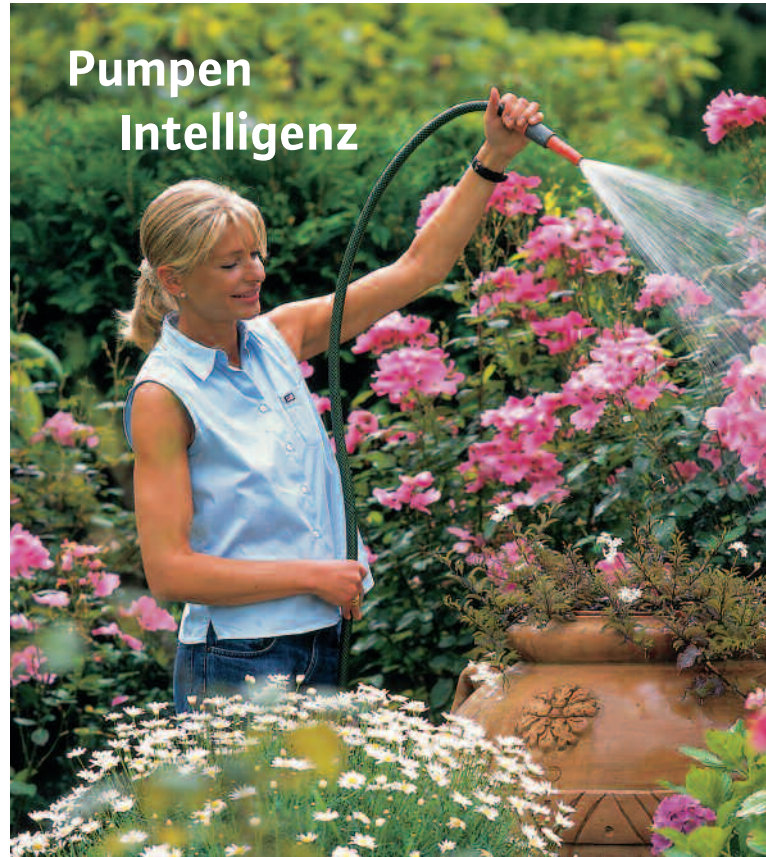

Wilo-TM/TMW



Basement drainage pump 2-pole.

Description

Particularly in applications with clear and drainage water, the Twister shows its strengths in automatic pump operation for draining collecting sumps, pits and tanks.

The patented design of the Wilo-Drain TMW 32 Twister ensures constant turbulence in the suction area of the pump, thus keeping the pump sump clean and free of unpleasant odours at all times. Therefore, the problem of sludge accumulation in the sump caused by the suspended matter in the water is a thing of the past. The forced-flow casing cooled, stainless steel-cased, dry electric motor with integrated thermal overload protection and automatic restart ensures the highest degree of dependability. (Option: HD version for aggressive media).

Technical Data

Performance	Wilo Drain			
	TM 25/6(A)	TMW 32/8	TMW 32/11	TMW 32/11HD
Twister Turbulator	-	•	•	•
Rated motor power P ₂ [kW]	0.1	0.37	0.55	0.55
Nominal current I ₁ ~230 V [A]	0.8	2.1	3.6	3.6
Fluid temperature [°C]	3-35	3-35	3-35	3-35
For short periods up to 3 minutes [°C]	-	90	90	90
Solid matter grain size [mm]	3	10	10	10
Max. submersion depth [m]	5	3	3	3

Application

Pumping clear or slightly soiled water from tanks, shafts or pits with the pump installed vertically. The patented Turbulator ensures that the sump is clean at all times!



Approved Fluids

- Washing machine soap and water mixture (without long-fibre particles)
- Non-oil based
- Non-chlorinated pool water
- Water from fire fighting systems
- Heating water (T_{max} = 35 °C)
- Boiler feed water - HD version only
- Cooling water
- Clean water
- Untreated sewage - no solids
- Drainage water
- Rainwater
- Wastewater
- Aggressive media (HD version)

Performance	Wilo Drain			
	TM 25/6(A)	TMW 32/8	TMW 32/11	TMW 32/11HD
Protection class for max. submersion depth	IP 68	IP 68	IP 68	IP 68
Insulation class	B	F	F	F
Cut-in level ± 8 [mm]	-	250	280	280
Cut-out level h ₁ ± 8 [mm]	-	102	102	102
Min. drain level [mm]	5	30	30	30
Weight [kg]	5.8 (5.9)	4.7	6.2	6.2
Frequency switching max. per hour	50	60	60	60
Activation type	Direct			
Operating mode	Intermittent duty S3; VDE 530 T1			
Cable type	H07RNF	H05RNF	H05RNF	H07RNF
Cable length [m]/plug	5	3	3	10
Attached float switch	- (+)	•	•	•
Built-in check valve body	•	•	•	•
Discharge port DN				
Pipe connection	Rp 1	Rp 1 ^{1/4}	Rp 1 ^{1/4}	Rp 1 ^{1/4}
Hose connection [ø in mm]	20/25	-	-	-
Overall height L [mm] (up to connection)	219	293	323	323
Pump diameter [mm]	155	165	165	165
Sump dimensions				
H min. [mm]	280	280	330	330
W min. [mm]	350 x 350	350 x 350	350 x 350	350 x 350

Pump Curves

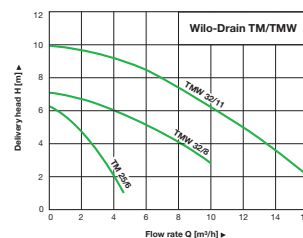

Deactivating the Twister Turbulator (see installation and operating manual) raises the pump curve by one meter.

Wilo-Drain TMW 32 pumps are exceptional:

Completely pre-assembled

Safe electrical connection

Easy operation

Operating reliability



Wilo-DrainLift Con



Automatic condensate lifting plant

Set-up/mounting

The plant can be installed free-standing or horizontally wall-mounted with two fastening holes.

The position of the motor unit on the tank is reversible, allowing a variable inlet and outlet.

The Wilo-DrainLift Con works particularly quietly, thus making it exceptionally well suited for systems in single-family and two-family homes.

Application

Because of modern heating and air-conditioning technology, condensate forms more frequently in oil and gas-fired condensing boilers, and air-conditioning and refrigeration systems, below the backflow level. Now, this condensate can be removed with no problem.

It must be used if disposal is not possible via natural gravity flow, or if the installation location is below the backflow level.

Because of the materials used in the manufacture of the plant, condensate with a pH value of down to 2.4 can be conveyed without any problems. For oil-fired boilers or gas-fired boilers with an output > 200 kW, the lifting unit must be installed downline of a neutralisation system.



Technical Data

Performance	
Current type	1~230 V, 50 Hz
Connected load	80 W
Nominal current	0.8 A
Operating mode	Intermittent duty S3
Dimensions W/H/D	195/170/130 mm
Gross volume	1.5 litres
Connecting cables	2 m power cable 1 m alarm signal
Delivery head max.	6 m
Flow rate max.	370 l/h
Medium	Strongly acid /acetous condensate (pH>2,4)
Medium temperature	max. 80 °C
Weight	2 kg
Material	ABS
Connections	
2 inlets in the cover	19 and 24 mm
Discharge side	Hose connection NW 10 mm with built-in non-return valve

Options

Inlet adapter	DN 25/24 mm DN 32/24 mm DN 40/24 mm
---------------	-------------------------------------------

Accessories



Inlet adapter for variable inlet



25 m discharge hose

Wilo-DrainLift Con - an exceptional package



Completely pre-assembled

Tank, pump and cable are completely pre-assembled – an inlet adapter is optional.



Flexible application

Just set it up and connect it anywhere condensate forms.

You can use it in the heating or cooling chamber, in the boiler or under the evaporator.



Easy installation

Easy to mount on the wall, in the boiler or just set it up – connect the variable hose lines to two inlet openings, and you are done.



Operating reliability

The built-in alarm contact can be connected directly in the condensing boiler or to provide an external signal.



Safe electrical connection

The Wilo-DrainLift Con is ready to plug in – all you need is a socket.

Pump Curve

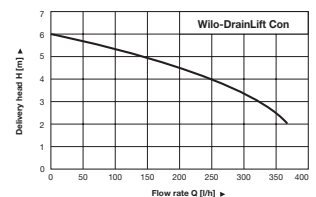

Wilo-DrainLift Box



Automatic wastewater lifting plant

Underfloor installation.

Application

Wastewater lifting plant with built-in submersible pump for automatic drainage of flood prone rooms, basement hatchways and showers, wash basins etc. in new and existing buildings for underfloor installation.



Technical Data

Performance	Wilo-DrainLift Box		
	32/8	32/11	40/10
Flow rate Q max. [m ³ /h]	10	16	18
Delivery head H max. [m]	7	10	10.5
Medium temperature [°C]	35	35	35
for short periods up to 3 min. [°C]	90	90	–
Rated motor power P ₂ [kW]	0.37	0.55	0.6
Nominal current I 1~230 V [A]	2.2	3.6	4.4
Solid matter grain size [mm]	10	10	35
Cable length [m] with plug	10	10	5

Collector tank

Gross volume [l]	85	85	85
Effective volume [l]	22	22	30

Materials

Tank	Polyethylene
Cover with intermediate case and tile frame	Galvanised steel
Floor drain with anti-siphon trap	Polyethylene

Approved Fluids

- Domestic sewage not containing faeces
- Washing machine soap and water mixture (without long-fibre particles)
- Non-chlorinated shower and bath water

Pump Curves

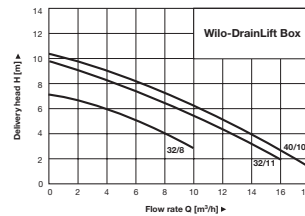

Wilo-DrainLift TMP 32



Description

The Wilo-DrainLift TMP is designed specifically for drainage of washing machines and dishwashers that cannot be connected directly to a waste pipe.

Approved Fluids

- Domestic sewage not containing faeces
- Washing machine soap and water mixture (without long-fibre particles)
- Non-chlorinated shower and bath water

Wastewater lifting plant

Above-floor installation.

Application

Wastewater lifting plant in a contemporary design for automatic drainage of showers, washstands, washing machines/ dishwashers, etc. in new and existing buildings.



Pump Curves

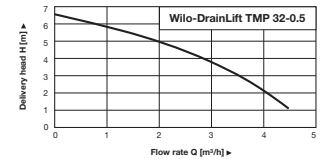

Technical Data

Performance	
Current type	1~230 V, 50 Hz
Connected load	0.33 kW
Nominal current I	1.5 A
Operating mode	Continuous duty S1 (1000 h)
Dimensions W/H/D	510/300/270 mm
Connecting cable length	1.2 m shockproof plug
Effective volume	2.6 litres
Delivery head H max.	6.5 m
Flow rate max.	4.5 m ³ /h
Medium temperature max.	45 °C (for short periods up to 3 min. 75 °C)
Solid matter grain size max.	10 mm
Protection class	IP 44
Weight	7.1 kg
Material	Styron 457
Colour	White (RAL 9003), high gloss

Connections

Inlet side	2 inlets G 1½ (DN 40) including cover plates
Discharge side	Delivery connection G 1¼ (DN 32)
Ventilation	Alternatively, built-in active carbon filter or separate vent line (ø 25 mm)

Wilo-DrainLift KH



Mini sewage lifting plant

Description

The Wilo-DrainLift KH is ideal for individual toilets where disposal through natural gravity flow is not possible. With its modern, attractive bathroom design, this system is a perfect visual accompaniment to plumbing fixtures.

Just connect it behind the free-standing WC, and you can pump waste to a distance of up to 50 m through pipes with a diameter of DN 32.

Application

Ready-to-use, limited-use lifting plant for wastewater containing faeces (for direct connection behind a toilet) with macerator for waste disposal from a single toilet and additional hand-washing basin, shower or bidet, from which the wastewater/sewage cannot be fed to the local sewer system using natural gravity flow, or that is below the backflow level.



Approved Fluids

- Domestic sewage not containing faeces
- Domestic sewage containing faeces
- Washing machine soap and water mixture (without long-fibre particles)
- Non-chlorinated shower and bath water

Technical Data

Performance

Current type	1~230 V, 50 Hz
Connected load	0.45 kW
Nominal current	2.1 A
Operating mode	Intermittent duty S3, 28 %/36 sec. in accordance with DIN, VDE 0530 T1
Dimensions W/H/D	510/300/270 mm
Connecting cable length	1.2 m shockproof plug
Effective volume	2.6 litres
Impoundment volume (lowest point to top edge of inlet)	15.5 litres
Delivery head max.	5.7 m
Volumetric flow rate max.	4 m ³ /h
Medium temperature	max. 35 °C
Protection class	IP 44 (optionally submersible)*
Weight	7.8 kg
Material	Styron 457
Colour	White (RAL 9003), high gloss

Technical Data

Connections

Inlet side	DN 100 (direct connection via sealing collar) 2 inlets DN 40 including cover plates and a non-return valve
Discharge side	Delivery connection for elbow hose connector DN 25/32 including built-in non-return valve
Ventilation	Alternatively, built-in active carbon filter or separate vent line (ø 25 mm)

* in this case, the air vent of the level switch must be located above the water level

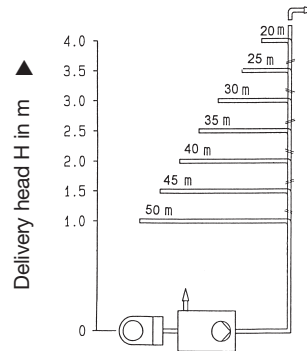

Max. pressure line length DN 32; for optimum operation, the pressure line should, if possible, be run vertically at first, and then continue horizontally. (This takes into consideration two 90° bends and a built-in non-return valve).

- Has to be installed directly behind a toilet which is installed below the back flow level
- Another toilet has to be installed above the backflow level
- Max. connectable units: 1 shower, 1 hand basin, 1 toilet, 1 bidet – all units have to be installed inside the same room

Pump Curves

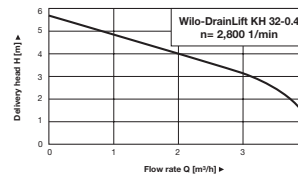

- Washing machines, dish washers and bath tubs must not be connected!



Wilо-DrainLift S



Sewage Lifting plant

Description

High-value, fully assembled sewage lifting plant in accordance with EN 12056. Suitable for handling untreated sewage which cannot be disposed of by natural gravity flow to the sewer system. Wilo-DrainLift S meets the requirements of EN 12050 as well as the construction and testing requirements of the German Institute for Building Technology. Minimal dimensions combined with optimised space requirements.

Application

- Retrofitting of showers, toilets, saunas, etc
- Installation of toilets in basement apartments
- Addition/renovation of apartments and buildings

Innovative combination of different installation options of sewage lifting plants into a single device, such as:

- Direct toilet connection
- Individual room drainage
- Free-standing installation/back-to-wall installation, combined in a single unit



Technical Data

Performance	Wilo DrainLift			
	S 1/5	S 1/7	S 1/5	S 1/7
Current type	1~230 V, 50Hz		3~400 V, 50Hz	
Connected load [kW]	1.25		1.1	
Nominal current I [A]	6.8		2.6	
Operating mode	S3			
Dimensions W/H/D [mm]	799/400/300			
Gross volume [l]	45			
Effective volume* [l]	20			
Residual volume [l]	6			
Delivery head H max. [m]	5	6.7	5	6.7
Flow rate Q max. [m³/h]	27	55	27	55
Medium temperature [°C]	35			
for short periods, up to [°C]	60			
Protection class	IP 67			
Weight [kg]	30			
Motor monitor	Thermal (motor monitor)			
Plug version	Additional motor protection			
Minimum inlet height* [mm]	135			
Cut-in level [mm]	180			
from lower edge				

Connections

Inlet side 2 inlets DN 40
1 inlet DN 100 can be freely chosen

Discharge side DN 80

Vent line DN 70

* in this case, the air vent of the level switch must be located above the water level

Approved Fluids

- Domestic sewage not containing faeces
- Domestic sewage containing faeces
- Washing machine soap and water mixture (without long-fibre particles)
- Non-chlorinated shower and bath water

Pump Curves

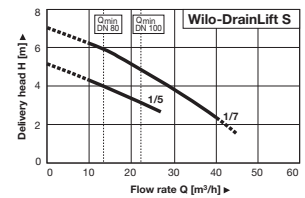



Pumpen Intelligenz.

WILO (U.K.) LTD
Second Avenue, Centrum 100,
Burton-on-Trent, DE14 2WJ
T: (01283) 523000 F: (01283) 523099
E: sales@wilo.co.uk
www.wilo.co.uk

For every home, every office, every building, every system...

WILO
Pumpen Intelligenz.

Domestic housing



For every application



For every home
www.wilo.co.uk

WILO
Pumpen Intelligenz.

Commercial property



For every application



For every office
www.wilo.co.uk

WILO
Pumpen Intelligenz.

Industrial property



For every application



For every building
www.wilo.co.uk

WILO
Pumpen Intelligenz.

Waste water and sewage



For every application



For every system
www.wilo.co.uk